

A471CR-50

Shower waste set, chrome

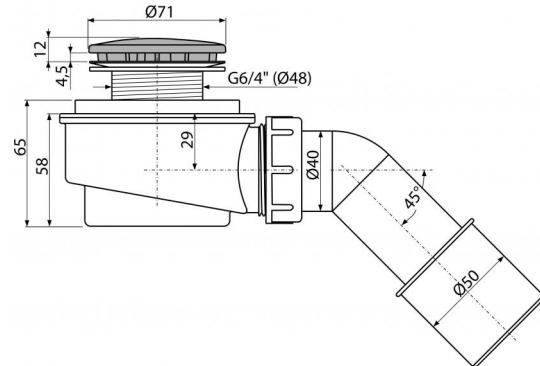

Application

To drain the water from the shower trays
 For shower trays without overflow
 For shower trays with a drain outlet Ø50 mm

Features

- Material: polypropylene, thermally and chemically resistant, longitudinally welded
- Self-cleaning design of trap
- Reduced installation height 65 mm

Scope of supply

- Elbow for connection to waste
- Assembly kit
- Chrome-plated plastic waste and trap cover
- Waste and trap body

Order number, Logistic information

Code	EAN	Weight (kus packing palett)	Dimensions (piece packing)	Quantity (packing palett)
A471CR-50	8595580523701	50 mm 0,2477 6,0075 188,2100 kg	170×100×170 590×240×390 mm	25 700 pcs

Guarantee

2/3 years

Customs code

39229000

Norms

EN 274

Technical specifications

- Flow rate 52 l/min
- Thermal resistance 95 °C
- Odour trap 35 mm